

Gas pressure switch C6097

TECHNICAL INFORMATION

- Monitoring of gas and air pressures (positive, negative and differential pressures)
- Switches with falling or rising pressure
- FM and UL certified: With lock-off and hand wheel with "WC/mbar scale
- EU certified pursuant to EN 1854: Hand wheel with mbar scale
- Suitable for hydrogen



Contents

| | | | |
|--|-----------|--|-----------|
| Contents | 2 | 6.2 Connecting set | 15 |
| 1 Application | 3 | 6.3 Restrictor orifice | 15 |
| 1.1 CE approved pressure switches | 4 | 6.4 Standard coupler plug set | 15 |
| 1.2 FM approved and UL listed pressure switches | 5 | 6.5 Standard coupler plug | 16 |
| 2 Application examples | 6 | 6.6 Pilot lamp, red/Pilot LED, blue | 16 |
| 2.1 Low gas pressure monitoring | 6 | 6.7 LED set, red/green | 16 |
| 2.2 Differential pressure monitoring | 6 | 6.8 Cover for auto reset | 16 |
| 2.3 Systems leak tightness check | 6 | 6.9 Cover for manual reset | 16 |
| 2.4 Air line with minimum pressure and flow monitoring .. | 7 | 6.10 Weather protection cover | 17 |
| 2.5 Low and high gas pressure protection | 7 | 7 Technical data | 18 |
| 3 Certification | 8 | 7.1 Recommended tightening torque | 18 |
| 3.1 Overview of product approvals | 8 | 7.2 EU certified pressure switches | 18 |
| 4 Function | 9 | 7.3 UL, FM certified pressure switches | 18 |
| 4.1 Vent limiter | 9 | 7.4 Adjusting range and switching hysteresis CE certified pressure switches | 19 |
| 4.2 Positive pressure measurement | 10 | 7.5 Adjusting range and switching hysteresis UL, FM certified pressure switches | 20 |
| 4.3 Negative pressure measurement | 10 | 7.5.1 C6097A type table | 20 |
| 4.4 Differential pressure measurement | 10 | 7.5.2 C6097B type table | 21 |
| 4.5 Connection diagrams | 11 | 8 Dimensions | 22 |
| 4.5.1 Contact position | 11 | 9 Converting units | 23 |
| 4.5.2 Blue pilot LED for 230 V AC or 115 V AC | 11 | 10 Maintenance cycles | 24 |
| 4.5.3 Red/green pilot LED for 24 V DC/AC or 110–230 V AC . | 11 | For more information | 25 |
| 4.6 Wiring | 11 | | |
| 5 Project planning information | 12 | | |
| 5.1 Installation position | 12 | | |
| 5.2 Installation | 12 | | |
| 5.3 Mechanical connection | 12 | | |
| 5.3.1 CE certified pressure switches | 12 | | |
| 5.3.2 UL, FM certified pressure switches | 13 | | |
| 5.4 Resetting pressure switches with manual reset | 13 | | |
| 5.5 Hydrogen | 14 | | |
| 6 Accessories | 15 | | |
| 6.1 Fastening set with screws, U-shape bracket | 15 | | |

1 Application



*C6097 with CE approval:
Hand wheel with mbar scale.
M16 cable gland for electrical connection.*



*C6097 with UL listing and FM approval:
Hand wheel with "WC and mbar scale.
1/2" NPT conduit for electrical connection.*



*C6097 with UL listing and FM approval:
C6097 can be supplied with lock-off function.*

The pressure switch monitors extremely low pressure differentials and triggers switch-on, switch-off or switch-over operations if a set switching point is reached. The switching point can be adjusted using a hand wheel.

The pressure switch monitors positive and negative gas pressures on various industrial gas and air appliances, such as boiler fan monitoring and differential pressure monitoring in firing, ventilation and air-conditioning systems.

Pressure switch C6097A switches in the event of decreasing pressure, C6097B switches in the event of increasing pressure.

Pressure switches with manual reset lock off after switching.

Pressure switches with an 0.2 mm (0.008") nozzle are supplied with an integrated vent limiter, see page 9 (4.1 Vent limiter).

1.1 CE approved pressure switches

| Type | Hand wheel setting/Switching properties | Positive pressure | Negative pressure |
|--|---|------------------------------|-------------------|
| C6097A4010 C6097A4110 C6097A4210 C6097A4310 C6097A4410 | Hand wheel set to decreasing pressure/ C6097 switches with rising and falling pressure | Gas, air, flue gas or biogas | Air, flue gas |

Electrical connection: Screw terminals and M16 cable gland

1.2 FM approved and UL listed pressure switches

| Type | Hand wheel setting/Switching properties | Positive pressure | Negative pressure |
|--|--|------------------------------|-------------------|
| C6097A3004 C6097A3053 C6097A3079 C6097A3137 | Hand wheel set to decreasing pressure/ C6097 switches with rising and falling pressure | Gas, air, flue gas or biogas | Air, flue gas |
| C6097A3012 C6097A3038 C6097A3095 C6097A3111 | Hand wheel set to decreasing pressure/ C6097 switches with falling pressure and locks off | Gas, air, flue gas or biogas | Air, flue gas |
| C6097B3002 C6097B3028 C6097B3051 | Hand wheel set to increasing pressure/ C6097 switches with rising pressure and locks off | Gas, air, flue gas or biogas | Air, flue gas |
| C6097B3085 C6097B3101 C6097B3119 | Hand wheel set to increasing pressure/ C6097 switches with rising and falling pressure | Gas, air, flue gas or biogas | Air, flue gas |

Electrical connection: Screw terminals 1/2" NPT conduit

2 Application examples

2.1 Low gas pressure monitoring

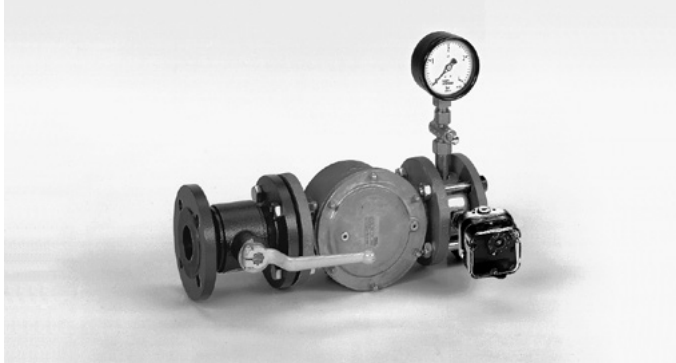

For monitoring the minimum gas inlet pressure

2.2 Differential pressure monitoring

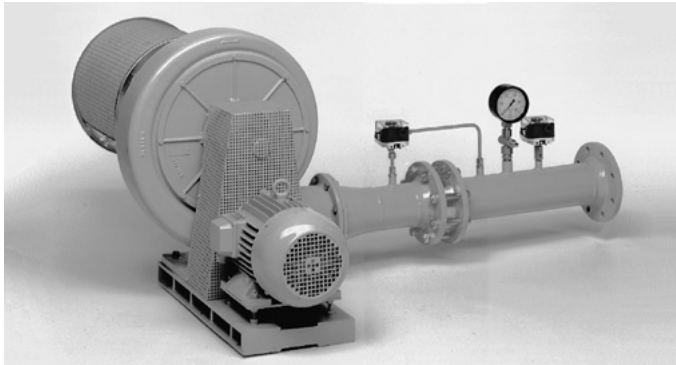

Differential pressure switch for monitoring air filters

2.3 Systems leak tightness check

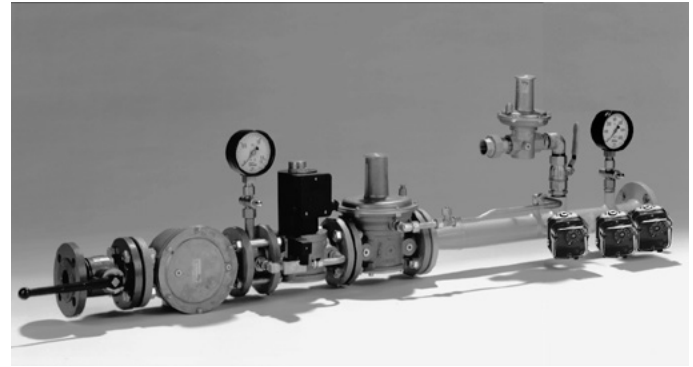

Electronic safety shut-off valve SSV with leak tightness check of downstream devices

2.4 Air line with minimum pressure and flow monitoring

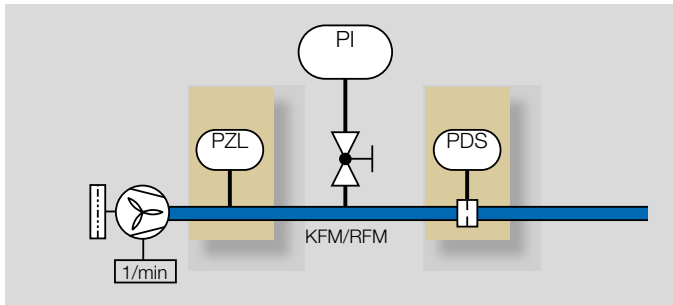

The air flow generated by the fan may be monitored as follows:

The static pressure is monitored by the pressure switch (PZL) as long as it can be demonstrated that the display consequently shows an adequate and secured flow of air, or the pressure switch (PDS) checks the flow of air via the differential pressure on the orifice.

If there is no air pressure supplied or if there is no differential pressure on the orifice, the system will be blocked.

2.5 Low and high gas pressure protection

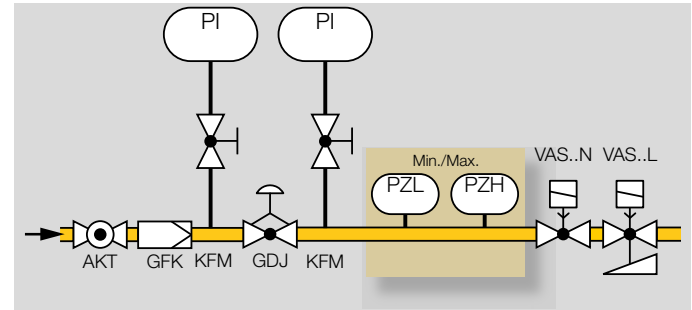

If the pressure is either too low or too high, the min./max. pressure switch (PZL/PZH) switches in order to avoid start-up or to initiate a safety shut-down.

3 Certification

Certificates – see www.docuthek.com

EU certified



- 2014/35/EU (LVD) – Low Voltage Directive
- 2014/30/EU (EMC) – Electromagnetic Compatibility Directive
- 2011/65/EU, RoHS II
- 2015/863/EU, RoHS III
- (EU) 2016/426 (GAR) – Gas Appliances Regulation
- EN 1854:2022+A1:2023

FM approved



Factory Mutual Research Klasse: 3510 Flow and pressure safety switches. Designed for applications pursuant to NFPA 85 and NFPA 86. www.approvalguide.com

UL listed

USA and Canada



Underwriters Laboratories – UL 353 „Limit Controls“. www.ul.com

3.1 Overview of product approvals

| | CE | FM APPROVED | C UL US LISTED |
|--|----|-------------|----------------|
| C6097A4110 C6097A4210 C6097A4310 C6097A4410 | • | - | - |
| C6097A3004 C6097A3012 C6097A3038 C6097A3053 C6097A3079 C6097A3095 C6097A3111 C6097A3137 C6097B3002 C6097B3028 C6097B3051 C6097B3085 C6097B3101 C6097B3119 | - | • | • |

4 Function

Pressure switch C6097A switches with falling pressure, C6097B switches with rising pressure.

Once the set switching point is reached, a micro switch is activated in the pressure switch which is designed as a change-over contact.

The switching pressure is adjusted using a hand wheel.

CE approved pressure switches

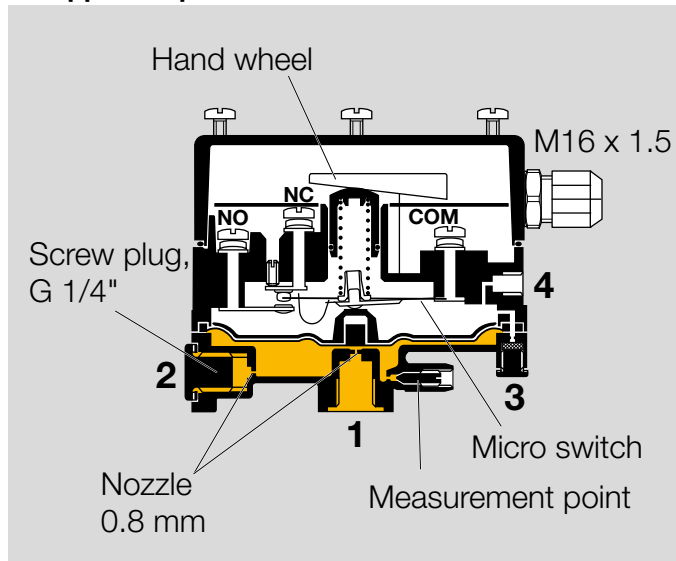

FM approved and UL listed pressure switches

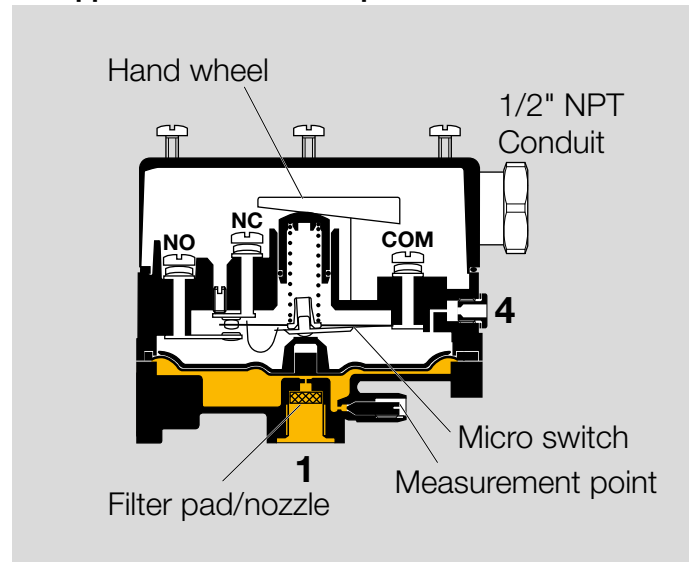

Pressure switches which lock off after switching can only be unlocked with a manual reset, see page 13 (5.4 Re-setting pressure switches with manual reset).

4.1 Vent limiter

The flow on FM approved and UL listed pressure switches is limited by the nozzle. In the event of a diaphragm tear, the escape of gas is limited to less than 1.0 CFH of natural gas, see max. inlet pressure, page 20 (7.5 Adjusting range and switching hysteresis UL, FM certified pressure switches).

4.2 Positive pressure measurement

Positive pressure measurement is designed, for example, for checking the fan function or measuring the min./max. pressure.

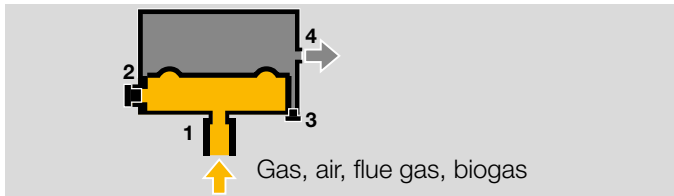

The positive pressure is measured in the lower diaphragm chamber, port 1 (or 2). The upper diaphragm chamber is ventilated via port 4 (or 3).

4.3 Negative pressure measurement

Negative pressure measurement (air, flue gas) is designed, for example, for monitoring a suction pressure blower.

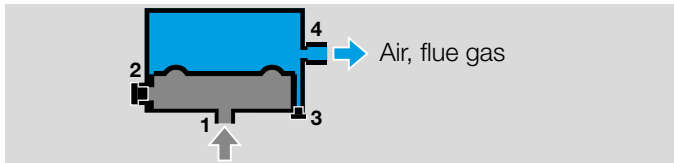

The negative pressure is measured in the upper diaphragm chamber, port 4 (or 3). The lower diaphragm chamber is ventilated via port 1 (or 2).

4.4 Differential pressure measurement

Differential pressure measurement is designed for safeguarding an air flow rate or for monitoring filters and fans, for example.

Do not connect port 4 (or 3) to pipes carrying gas! For further information, see "Project planning information", "Mechanical connection", page 12 (5.3.1 CE certified pressure switches).

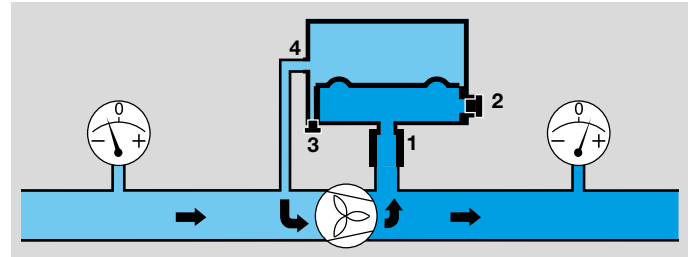
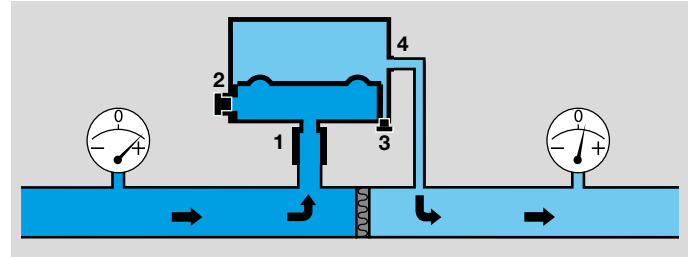

The higher absolute pressure is connected to port 1 (or 2), and the lower absolute pressure to port 4 (or 3). The remaining ports must be tightly plugged.

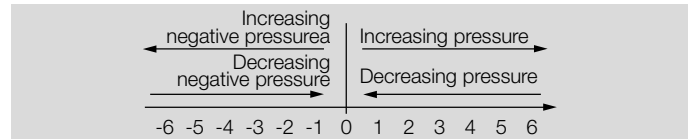

4.5 Connection diagrams

4.5.1 Contact position

Contacts 3 and 2 close when subject to increasing pressure.

Contacts 1 and 3 close when subject to falling pressure.

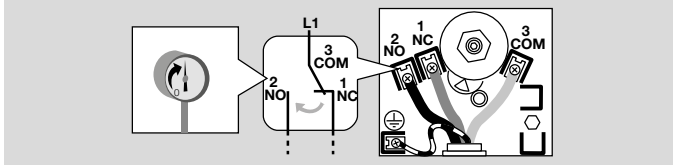

On pressure switches that switch with rising pressure:
The contact switches from NC 1 to NO 2.

On pressure switches that switch with falling pressure:
The contact switches from NO 2 to NC 1.

4.5.2 Blue pilot LED for 230 V AC or 115 V AC

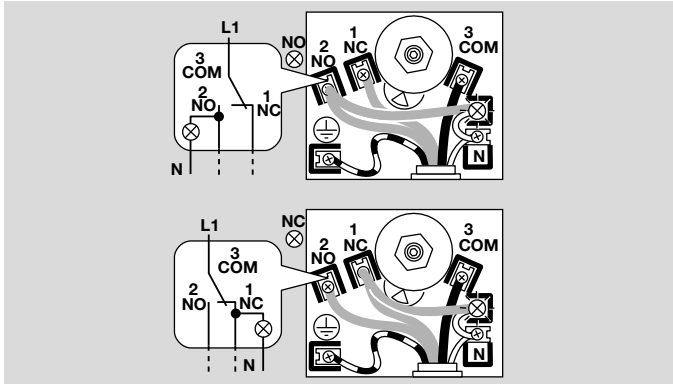

4.5.3 Red/green pilot LED for 24 V DC/AC or 110–230 V AC

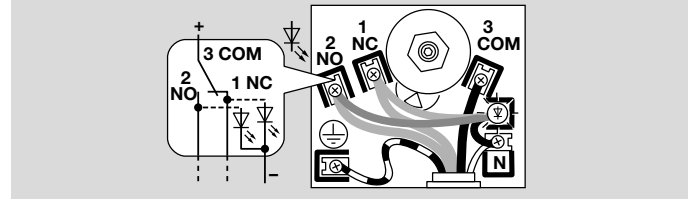

4.6 Wiring

When using silicone tubes, only use silicone tubes which have been sufficiently cured. Vapours containing silicone can adversely affect the functioning of electrical contacts.

In the case of low switching capacities, such as 24 V, 8 mA, for example, we recommend using an RC module (22 Ω, 1 μF) in air containing silicone or oil.

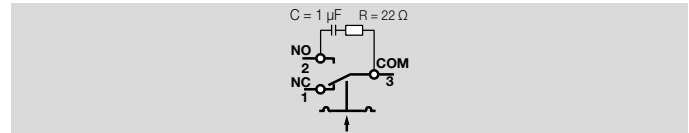

In the case of high humidity or aggressive gas components (H₂S), we recommend using a pressure switch with gold contact due to its higher resistance to corrosion. Closed-circuit current monitoring is recommended under difficult operating conditions.

5 Project planning information

5.1 Installation position

Installation in the vertical or horizontal position, or sometimes upside down, preferably with vertical diaphragm. If installed in a vertical position, the switching point p_S will correspond to the scale value SK set on the hand wheel. If installed in another position, the switching point p_S will change and no longer correspond to the set scale value SK. Switching point p_S must be checked.

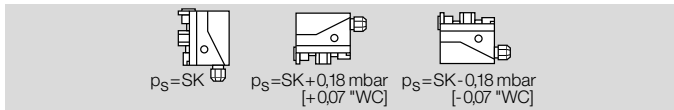

5.2 Installation

The housing must not be in contact with masonry. Minimum clearance 25 mm (1").

Long-term use in the upper ambient temperature range accelerates the ageing of the elastomer materials and reduces the service life (please contact manufacturer).

Continuous operation with gases containing more than 0.1 %-by-vol. H_2S or ozone concentrations exceeding $200 \mu g/m^3$ accelerate the ageing of elastomer materials and reduce the service life.

Vapours containing silicone can adversely affect the functioning of electrical contacts. When using silicone tubes, only use silicone tubes which have been sufficiently cured.

Condensation must not be allowed to get into the housing. If possible, install pipework with an ascending gradient). Otherwise, there is a risk of icing of condensation at sub-

zero temperatures, the switching point shifting or corrosion in the device which can lead to malfunctions.

When installing outdoors, place the pressure switch in a roofed area and protect from direct sunlight (even IP 65 version).

The weather protection cover provides permanent protection when installed outdoors. See page 17 (6.10 Weather protection cover).

In case of highly fluctuating pressures, install a restrictor orifice. See page 15 (6.3 Restrictor orifice).

5.3 Mechanical connection

5.3.1 CE certified pressure switches

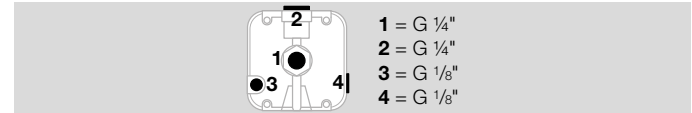

- 1 = G 1/4"
- 2 = G 1/4"
- 3 = G 1/8"
- 4 = G 1/8"

| Positive pressure | connect | seal | free* |
|-------------------|---------|------|--------|
| C6097 | 1 | 2 | 3 or 4 |
| C6097 | 2 | 1 | 3 or 4 |

| Negative pressure | connect | seal | free* |
|-------------------|---------|------|--------|
| C6097 | 4 | 3 | 1 or 2 |
| C6097 | 3 | 4 | 1 or 2 |

* It is recommended that the port which is best protected from water and dirt be left open.

5 Project planning information

| Differential pressure | connect | | seal |
|-----------------------|----------------------------------|---------------------------------|--------------------------------|
| | for the higher absolute pressure | for the lower absolute pressure | |
| C6097 | 1 or 2 | 3 or 4 | Seal ports that are not in use |

Ports **3** and **4** are connected to the micro switch chamber.

Pipes carrying gas must not be connected to port **3** or **4**!

The port that is best protected against soiling (dust/humidity) is to be left open for ventilation (positive pressure measurement) to the atmosphere.

5.3.2 UL, FM certified pressure switches



| Positive pressure | Connect | Free |
|-------------------|---------|------|
| C6097 | 1 | 4 |

| Negative pressure | Connect | Free |
|-------------------|---------|------|
| C6097 | 4 | 1 |

| Differential pressure | Connect | |
|-----------------------|----------------------------------|---------------------------------|
| | for the higher absolute pressure | for the lower absolute pressure |
| C6097 | 1 | 4 |

Port **4** is connected to the micro switch chamber.

For this reason, pipes carrying gas must not be connected to port **4**!

If necessary, port **4** (1/8" NPT) can be used to connect the venting line.

A filter pad at port **4** protects the electrical contacts in the pressure switch from dirt particles in the surrounding air or in the medium.

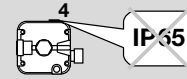

If port **4** is at the top, IP 65 will not be satisfied.

5.4 Resetting pressure switches with manual reset

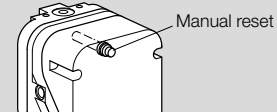

C6097A3012, C6097A3038, C6097A3095, C6097A3111 lock off if the pressure drops to the set switching point: For resetting, the pressure must have risen to at least the set switching point **plus** the pressure differential between the switching pressure and possible reset.

C6097B3002, C6097B3028, C6097B3051 lock off if the pressure rises to the set switching point: For resetting, the pressure must have dropped to at least the set switching point **minus** the pressure differential between the switching pressure and possible reset.

For details of the pressure differential between the switching pressure and possible reset, see page 19 (7.4 Adjusting range and switching hysteresis CE certified pressure switches).

5.5 Hydrogen



Other hydrogen-compatible products can be found here:
[Technical Information, Products for hydrogen.](#)

6 Accessories

6.1 Fastening set with screws, U-shape bracket

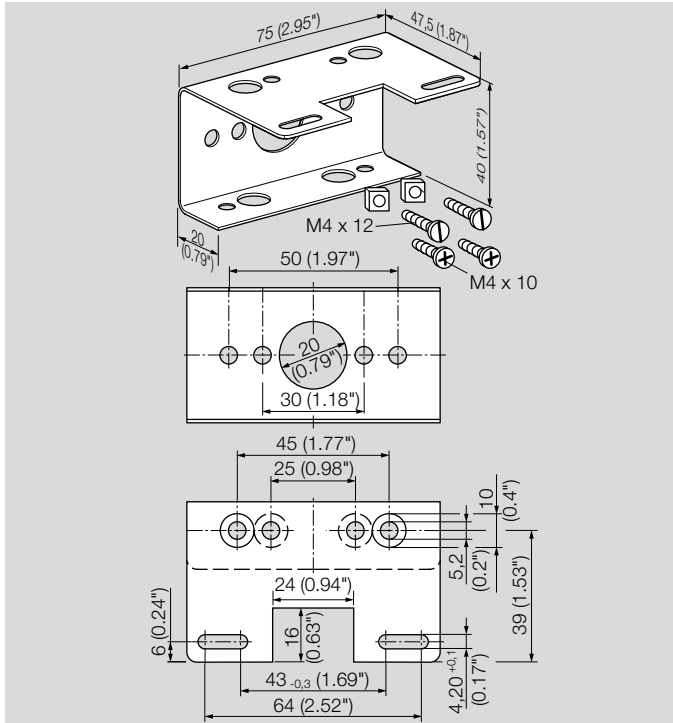

Order No.: 32003042-003/U.

6.2 Connecting set



For monitoring a minimum and maximum inlet pressure with two pressure switches attached to one another.

Order No.: 32003043-003/U.

6.3 Restrictor orifice

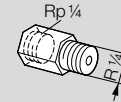

For CE certified pressure switches.

In the case of high pressure fluctuations, we recommend using a restrictor orifice (contains non-ferrous metals).

Hole diameter \varnothing 0.2 mm, Order No.: 32003051-003/U,

Hole diameter \varnothing 0.3 mm, Order No.: 32003052-003/U.

6.4 Standard coupler plug set

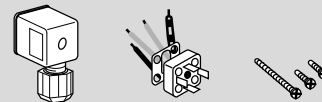

For CE certified pressure switches,

Order No.: 32003053-003/U.

For FM, UL certified pressure switches,

Order No.: 32003054-003/U.

6.5 Standard coupler plug

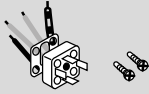

For CE certified pressure switches,
Order No.: 32003055-003/U.

For FM, UL certified pressure switches,
Order No.: 32003056-003/U.

6.6 Pilot lamp, red/Pilot LED, blue

Pilot lamp, red:

110/120 V AC, $I = 1.2 \text{ mA}$, Order No.: 32003044-003/U.

230 V AC, $I = 0.6 \text{ mA}$, Order No.: 32003046-003/U.

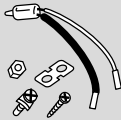

Pilot LED, blue:

115/230 V AC, $I = 0.24 \text{ mA}$ (110 V), $I = 0.5 \text{ mA}$ (230 V), Order
No.: 32003047-003/U.



6.7 LED set, red/green

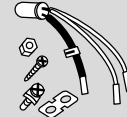

24 V DC, $I = 16 \text{ mA}$; 24 V AC, $I = 8 \text{ mA}$,
Order No.: 32003048-003/U.

110 to 230 V AC, Order No.: 32003049-003/U.

6.8 Cover for auto reset

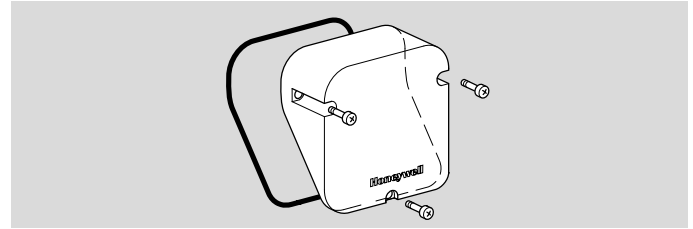

Order No.: 32003040-003/U.

6.9 Cover for manual reset

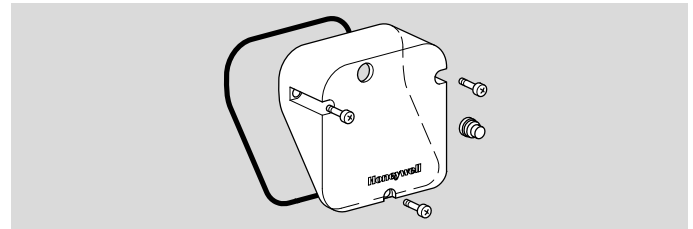

Order No.: 32003041-003/U

6.10 Weather protection cover

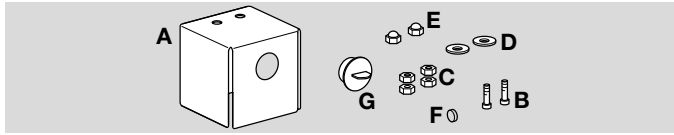

In the case of outdoor installation, the weather protection cover provides permanent protection against condensation and weathering of housing parts.

The weather protection cover is made of 1 mm-thick stainless steel.

The enclosed filter pad is designed to protect the open 1/8" port from the ingress of dirt or insects.

Scope of delivery:

A 1 x cover, 100 x 100 x 100 mm

B 2 x M4 x 16 screws

C 4 x nuts

D 2 x washers

E 2 x cap nuts

F 1 x filter pad (1/8" port)

G 1 x pull-tab plug

Order No.: 32003050-003/U

Installation position: vertical, with the cable gland pointing downwards.

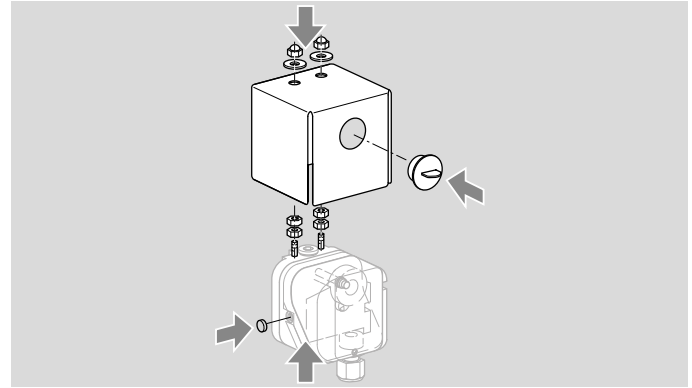

7 Technical data

Gas type: natural gas, town gas, LPG (gaseous), flue gas, biogas (max. 0.1 %-by-vol. H₂S), hydrogen and air.

Electrical connection type: screw terminals.

Diaphragm pressure switch, silicone-free.

Diaphragm: NBR.

Housing: glass fibre reinforced PBT plastic with low gas release.

Lower housing section: AISi 12.

Enclosure: IP 65. Safety class: 1.

Storage temperature: -20 to +40°C (-4 to +104°F).

Long-term use in the upper ambient temperature range accelerates the ageing of the elastomer materials and reduces the service life (please contact manufacturer).

The set switching point may noticeably change in media and ambient temperatures below -30°C (-22°F).

Weight: 270 to 320 g (9.5 to 11.3 oz) depending on equipment.

7.1 Recommended tightening torque

| Component | Tightening torque [Ncm] |
|--|-------------------------|
| Cover screws | 50 |
| M16 x 1.5 cable gland | 30 |
| ½" NPT conduit | 170 (15 lb") |
| G 1/8 connection on aluminium lower section | 300 |
| G 1/4 connection (1/4" NPT) on aluminium lower section | 2400 |
| G 1/8 connection on upper housing section | 300 |
| Clamping terminal screws | 80 |
| T15 test point screw | 250 |

7.2 EU certified pressure switches

Max. inlet pressure $p_{max.}$ = withstand pressure, see adjusting range, page 19 (7.4 Adjusting range and switching hysteresis CE certified pressure switches).

Cable diameter: AWG 24 to AWG 13, 0.5 to 1.8 mm (0.02 to 0.07").

Maximum medium and ambient temperatures: -20 to +80°C (-4 to +176°F).

Switching capacity:

U = 24–250 V AC,

I = 0.05–5 A at $\cos \varphi = 1$,

I = 0.05–1 A at $\cos \varphi = 0.6$.

Line entrance:

M16 x 1.5 cable gland,

clamping range: diameters of 4 to 10 mm.

7.3 UL, FM certified pressure switches

Max. inlet pressure $p_{max.}$ = withstand pressure, see adjusting range, page 20 (7.5 Adjusting range and switching hysteresis UL, FM certified pressure switches).

Maximum medium and ambient temperatures: -40 bis +60 °C (-40 bis +140 °F).

switching capacity:

U = 24–240 V AC,

I = max. 5 A at $\cos \varphi = 1$

I = max. 0,5 A at $\cos \varphi = 0,6$.

Line entrance: 1/2" NPT Conduit.

Cable diameter: AWG 24 to AWG 13, 0.5 to 1.8 mm (0.02 to 0.07").

7.4 Adjusting range and switching hysteresis

CE certified pressure switches

| Type | Adjusting range* | Mean switching differential at min. and max. setting | Max. inlet pressure $p_{\max.}$ = withstand pressure | Deviation from the switching point during testing pursuant to EN 1854 |
|------------|-----------------------------|--|--|---|
| C6097A4010 | 40–600 Pa (0.4–6 mbar) | 20–30 Pa (0.2–0.3 mbar) | ± 10 kPa (100 mbar) | ± 15 % |
| C6097A4110 | 100–1000 Pa (1–10 mbar) | 25–40 Pa (0.25–0.4 mbar) | ± 50 kPa (500 mbar) | ± 15 % |
| C6097A4210 | 0.25–5 kPa (2.5–50 mbar) | 0.08–0.15 kPa (0.8–1.5 mbar) | ± 50 kPa (500 mbar) | ± 15 % |
| C6097A4310 | 3–15 kPa (30–150 mbar) | 0.3–0.5 kPa (3–5 mbar) | ± 60 kPa (600 mbar) | ± 15 % |
| C6097A4410 | 10–50 kPa (100–500 mbar) | 0.8–1.7 kPa (8–17 mbar) | ± 60 kPa (600 mbar) | ± 15 % |

* Adjusting tolerance = ± 15% of the scale value.

Switching properties, see Application page 4 (1.1 CE approved pressure switches).

7.5 Adjusting range and switching hysteresis UL, FM certified pressure switches

For further information, see Application page 5 (1.2 FM approved and UL listed pressure switches).

7.5.1 C6097A type table

Switching properties at setpoint value: NO-to-COM connection is interrupted if the pressure drops.

| Type | Adjusting range* | Mean switching differential at min. and max. setting | Max. inlet pressure | | Lock-off | Difference between switching pressure and possible lock-off | Medium | NPT |
|------------|---------------------|--|-------------------------------|----------------------------------|----------|---|---------|------|
| | "WC (mbar) | "WC (mbar) | with venting line, psi (mbar) | without venting line, psi (mbar) | | "WC (mbar) | | |
| C6097A3004 | 0.4–4 (1–10) | 0.1–0.16 (0.25–0.4) | 8.5 (600) | 7 (480) | No | – | Air/gas | 1/4" |
| C6097A3012 | 1–20 (2.5–50) | – | 8.5 (600) | 7 (480) | Yes | 0.4–0.8 (1–2) | Air/gas | 1/4" |
| C6097A3038 | 12–60 (30–150) | – | 8.5 (600) | 7 (480) | Yes | 0.8–4.8 (2–12) | Air/gas | 1/4" |
| C6097A3053 | 1–20 (2.5–50) | 0.3–0.6 (0.75–1.5) | 8.5 (600) | 7 (480) | No | – | Air/gas | 1/4" |
| C6097A3079 | 12–60 (30–150) | 1.2–2 (3–5) | 8.5 (600) | 7 (480) | No | – | Air/gas | 1/4" |
| C6097A3095 | 0.4–4 (1–10) | – | 8.5 (600) | 7 (480) | Yes | 0.16–0.4 (0.4–1) | Air/gas | 1/4" |
| C6097A3111 | 40–200 (100–500) | – | 8.5 (600) | 7 (480) | Yes | 2–7.2 (5–18) | Air/gas | 1/4" |
| C6097A3137 | 40–200 (100–500) | 3.2–6.8 (8–17) | 8.5 (600) | 7 (480) | No | – | Air/gas | 1/4" |

* Adjusting tolerance = ± 15% of the scale value.

7.5.2 C6097B type table

Switching properties at setpoint value: NC-to-COM connection is interrupted if the pressure rises.

| Type | Adjusting range* | Mean switching differential at min. and max. setting | Max. inlet pressure | | Lock-off | Difference between switching pressure and possible lock-off | Medium | NPT |
|------------|---------------------|--|-------------------------------|----------------------------------|----------|---|---------|------|
| | | | with venting line, psi (mbar) | without venting line, psi (mbar) | | | | |
| C6097B3002 | 12–60 (30–150) | – | 8.5 (600) | 7 (480) | Yes | 0.8–4.8 (2–12) | Air/gas | 1/4" |
| C6097B3028 | 1–20 (2.5–50) | – | 8.5 (600) | 7 (480) | Yes | 0.4–0.8 (1–2) | Air/gas | 1/4" |
| C6097B3051 | 40–200 (100–500) | – | 8.5 (600) | 7 (480) | Yes | 2–7.2 (5–18) | Air/gas | 1/4" |
| C6097B3085 | 12–60 (30–150) | 1.2–2 (3–5) | 8.5 (600) | 7 (480) | No | – | Air/gas | 1/4" |
| C6097B3101 | 40–200 (100–500) | 3.2–6.8 (8–17) | 8.5 (600) | 7 (480) | No | – | Air/gas | 1/4" |
| C6097B3119 | 1–20 (2.5–50) | 0.3–0.6 (0.75–1.5) | 8.5 (600) | 7 (480) | No | – | Air/gas | 1/4" |

* Adjusting tolerance = $\pm 15\%$ of the scale value.

8 Dimensions

EU certified pressure switches

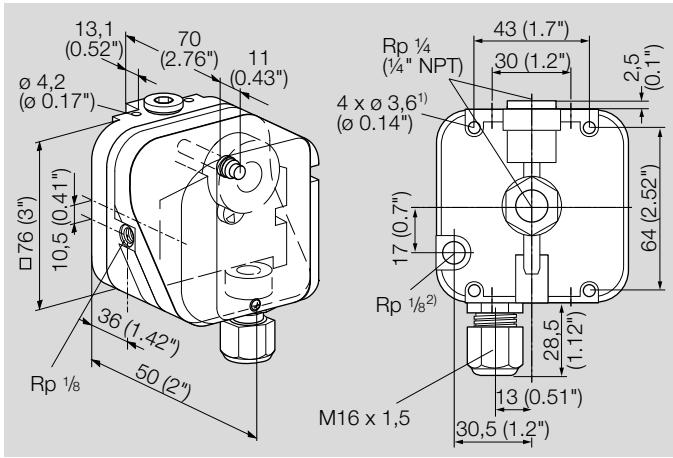

1) Holes 10 mm (0.4") deep, for self-tapping screws.

UL, FM certified pressure switches

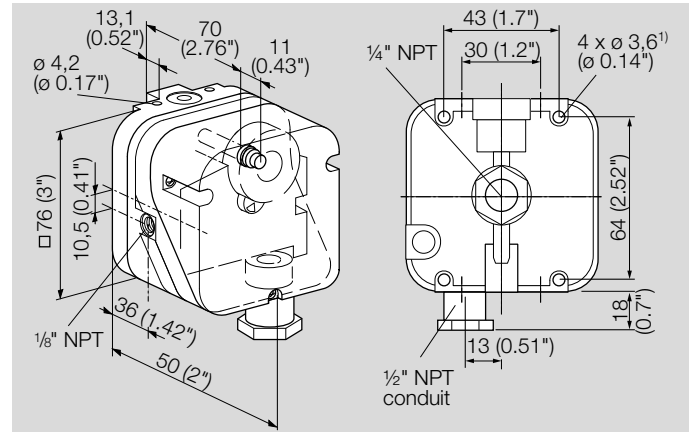

1) Holes 10 mm (0.4") deep, for self-tapping screws.

9 **Converting units**

See www.adlatus.org

10 Maintenance cycles

At least once a year, at least twice a year in the case of biologically produced methane.

For more information

The Honeywell Thermal Solutions family of products includes Honeywell Combustion Safety, Eclipse, Exothermics, Hauck, Kromschroder and Maxon. To learn more about our products, visit ThermalSolutions.honeywell.com or contact your Honeywell Sales Engineer.

Elster GmbH
Strotheweg 1, D-49504 Lotte
T +49 541 1214-0
hts.lotte@honeywell.com
www.kromschroeder.com

© 2025 Elster GmbH

We reserve the right to make technical modifications in the interests of progress.

